

ghibli & wirbel

Professional Cleaning Machines Since 1968

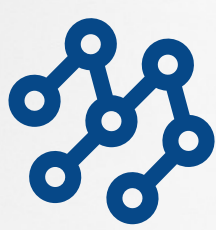

g&w

Fleet4You



ghibli & wirbel

Dashboard Overview

- Dashboard
- Reports
- Users
- Settings
- Help

Device	Status	Location	Operator	Start Time	End Time	Duration	Cost
1234567890123456	Online	New York St	John Doe	10:00	11:00	01:00	\$10.00
1234567890123456	Offline	New York St	John Doe	10:00	11:00	01:00	\$10.00
1234567890123456	Online	New York St	John Doe	10:00	11:00	01:00	\$10.00
1234567890123456	Online	New York St	John Doe	10:00	11:00	01:00	\$10.00
1234567890123456	Online	New York St	John Doe	10:00	11:00	01:00	\$10.00

Summary: 5 devices, 100% online, 100% available

G&W FLEET 4 YOU

THE FLEET MANAGEMENT SYSTEM DESIGNED FOR YOU!

G&W FLEET 4 YOU IS THE FLEET MANAGEMENT SYSTEM
THAT ALLOWS USERS TO:



**HAVE A WEALTH OF DATA
AND INFORMATION ON THE WORK
PERFORMED BY THE MACHINES**



**ANALYZE USES AND IMPROVE
THE EFFICIENCY OF THE VARIOUS
CLEANING OPERATIONS**



**MONITOR THE ENTIRE FLEET
OR INDIVIDUAL MACHINES
AT ANY GIVEN MOMENT**

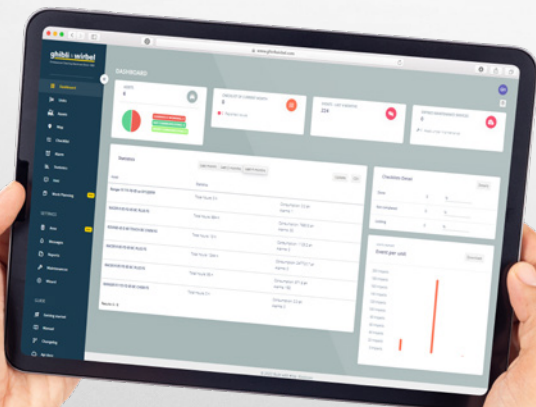

A COMPLETE, FEATURE-RICH SYSTEM PACKED IN TWO SIMPLE DEVICES

G&W FLEET 4 YOU

The device, which is connected to the battery of the machines, is installed directly in the Ghibli & Wirbel factory during the production phase (it is not possible to apply this system to previously purchased scrubber dryers). The device is equipped with an accelerometer for shocks detection, a current sensor to count working hours and an electrolyte sensor for analyzing battery charge cycles.



KEY 4 YOU

The Key 4 You electronic badge with magnetic ring (available in **Fleet & Key 4 You** and **Key 4 You** versions) allows the user to control the access to the machine on which it is installed. By increasing the number of Key 4 You devices, it is hence possible to allow multiple people access to the same machine. In this way only authorized personnel will be able to use the scrubber dryers in the fleet.



G&W FLEET 4 YOU CAN BE PURCHASED IN TWO DIFFERENT PACKAGES:

1. Fleet 4 You (96.0212.00)

It includes the complete fleet management system and the access to the G&W Fleet 4 You Connect portal for 12 months, after which the subscription will have to be renewed.

2. Fleet & Key 4 You (96.0213.00)

To the services offered by the standard version is added the Key 4 You electronic badge, which allows the user to control the accesses to the machine on which it is installed. In this way, only authorized personnel will be able to use the scrubber dryers. The use of the G&W Fleet 4 You Connect portal is included for 12 months, after which the subscription will have to be renewed.

TO WHICH CAN ALSO BE ADDED:

Key 4 You (96.0215.00)

Electronic badge that can be purchased individually in addition to those available in the Fleet & Key 4 You version.

Fleet 4 You Connected (96.0214.00)

Subscription renewal on a monthly basis.



G&W FLEET 4 YOU CAN BE INSTALLED ON GIBLI & WIRBEL SCRUBBER DRYERS STARTING FROM ROUND 45 TO R 300.



G&W FLEET 4 YOU

DATA COLLECTION AND EFFICIENCY OPTIMIZATION OF THE CLEANING PROCESS

The device installed on the machines is interconnected with the remote control cloud in order to collect the data on the use of the machines which is then processed and transformed into useful information to be returned to the fleet management user.

It is possible to obtain data on the **activity status** of the scrubber drier and its **location**, **hours of work**, **battery status** and **style of driving** (e.g. in case of collisions) using the sensors installed on the machine.

The information available to the user make it possible to assess the utilization of the individual machine and/or the entire fleet and set up the most effective and efficient cleaning process by planning the various activities.

COST REDUCTION

Thanks to **continuous monitoring** of the machines and regular data **analysis** costs can be reduced, by also eliminating waste situations. As a matter of fact, without optimization of the cleaning operations, the risk of inefficiencies and consequent additional costs vastly increases.



SECURITY

The **Key 4 You** electronic badge with magnetic ring gives the user the ability to **control the access** to the machine, improving the security by ensuring that only authorized personnel can use the scrubber dryers. In addition, in case of theft, it is possible to lock the scrubber dryers remotely.



THE BENEFITS OF INTERCONNECTION



REMOTE AND REAL-TIME FLEET MANAGEMENT AND MONITORING

The management and control of the machines is easy and immediate for all users of the G&W Fleet 4 You system, with significant benefits in terms of **work optimization**. Data on the usage of each machine is collected in real time from the device, allowing the user to take immediate action in case of anomalies, collisions or misuse of the scrubber dryers. Outside of the European Union the data collection takes place about every hour and a half. It is also possible to **schedule machine maintenance**, organizing at the best the different stages according to the time required for each operation, avoiding sudden downtime situations.



SATELLITE TRACKING AND WORK AREA MANAGEMENT

- **GNSS tracking** makes it possible to monitor routes and control machine work areas. With G&W Fleet 4 You the fleet manager can easily pinpoint the location of the affected scrubber dryers and assign each machine and/or users to different work areas.
- The **Work areas (ADL)**, which can be configured on the map by drawing an area of any shape and size, allows the user to manage the machine work on different dates, times and days of the week, and monitor the time the scrubber dryer is in a specific location.



ANALYSIS AND REPORTS

G&W Fleet 4 You allows you to have statistics and **analysis of the data collected** at all times: measuring the efficiency and productivity of your machines has never been easier and faster! In addition, the reporting functions are highly customizable and the manager can decide to receive summary e-mails on a daily, weekly or monthly basis.

G&W FLEET 4 YOU CONNECT

G&W FLEET 4 YOU CONNECT IS THE FLEET MANAGEMENT CLOUD PORTAL, ACCESSIBLE FROM BOTH PC AND SMARTPHONES, WHICH ALLOWS THE COLLECTION AND ANALYSIS OF DATA SENT FROM THE G&W FLEET 4 YOU DEVICE THROUGH GPRS CONNECTIVITY (SIM 4G). ALL THE KEY INFORMATION ARE GATHERED IN A SINGLE SCREEN PAGE FOR USER CONVENIENCE

CHECKLIST OF CURRENT MONTH

number of checklists for which completion was requested and number of problems reported

ASSETS

total number of the scrubber dryers that make up the fleet and number of machines currently working

STATISTICS

to optimize the management of the machine fleet

MENU

to manage the main functions of the portal in a simple and intuitive way

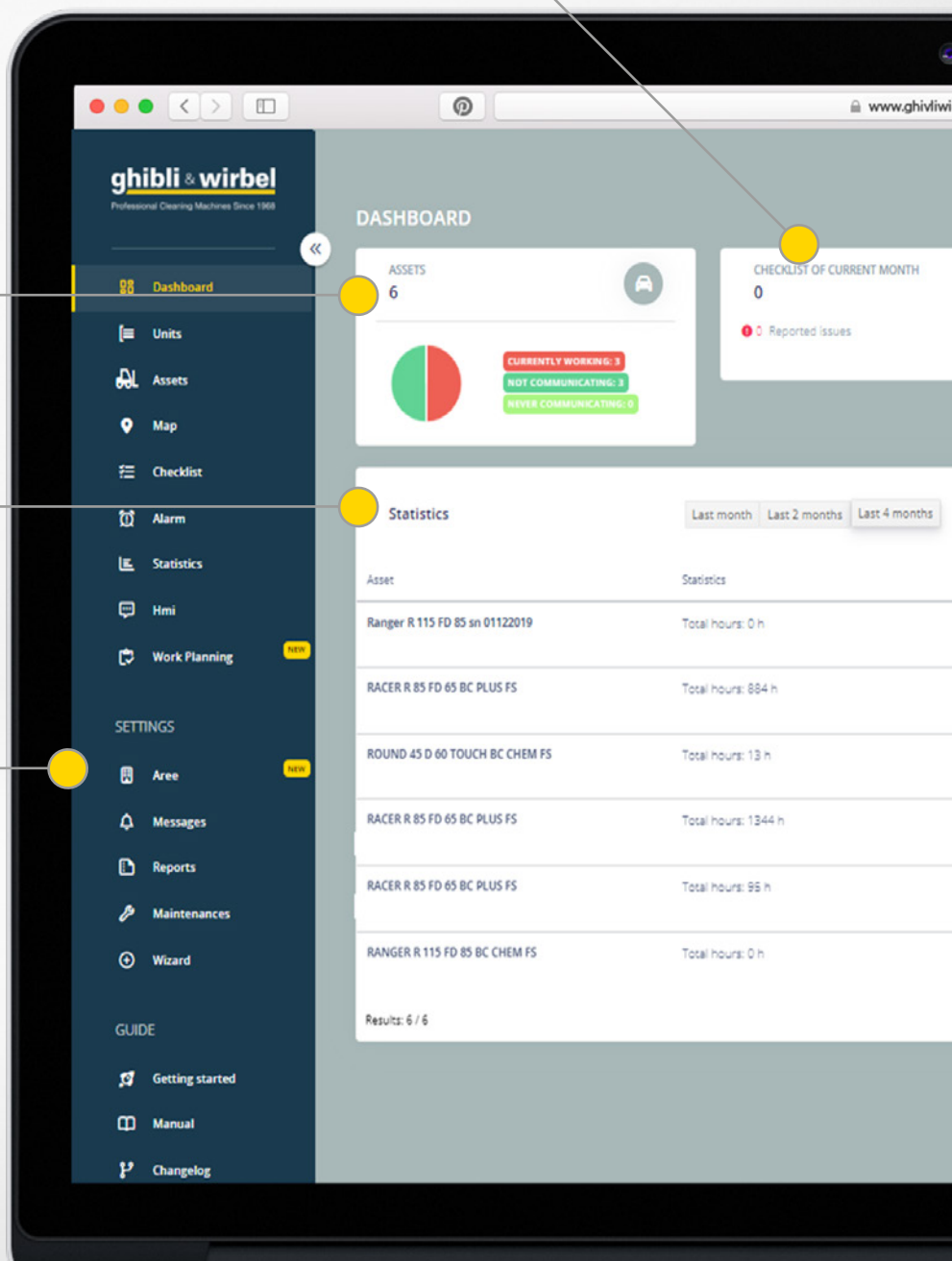

THANKS TO THE INTERCONNECTION BETWEEN THE DEVICE AND THE G&W FLEET 4 YOU CONNECT IT IS POSSIBLE TO VIEW THE STATUS OF THE MACHINE (E.G. WORKING HOURS, BATTERY ANALYSIS, COLLISIONS OCCURRED, ETC.) AND SCHEDULE MAINTENANCE ACTIVITIES

EVENTS

occurred in the last 4 months (collisions, anomalies, etc...)

ACCOUNT

credentials and access link can be obtained by mailing service@ghibliwirbel.com

The portal is available in 9 languages (Italian, English, French, Spanish, German, Hungarian, Polish, Romanian and Serbian) selectable from the drop-down menu

EXPIRED MAINTENANCE SERVICES

fleet machines that need maintenance work

CHECKLIST DETAIL





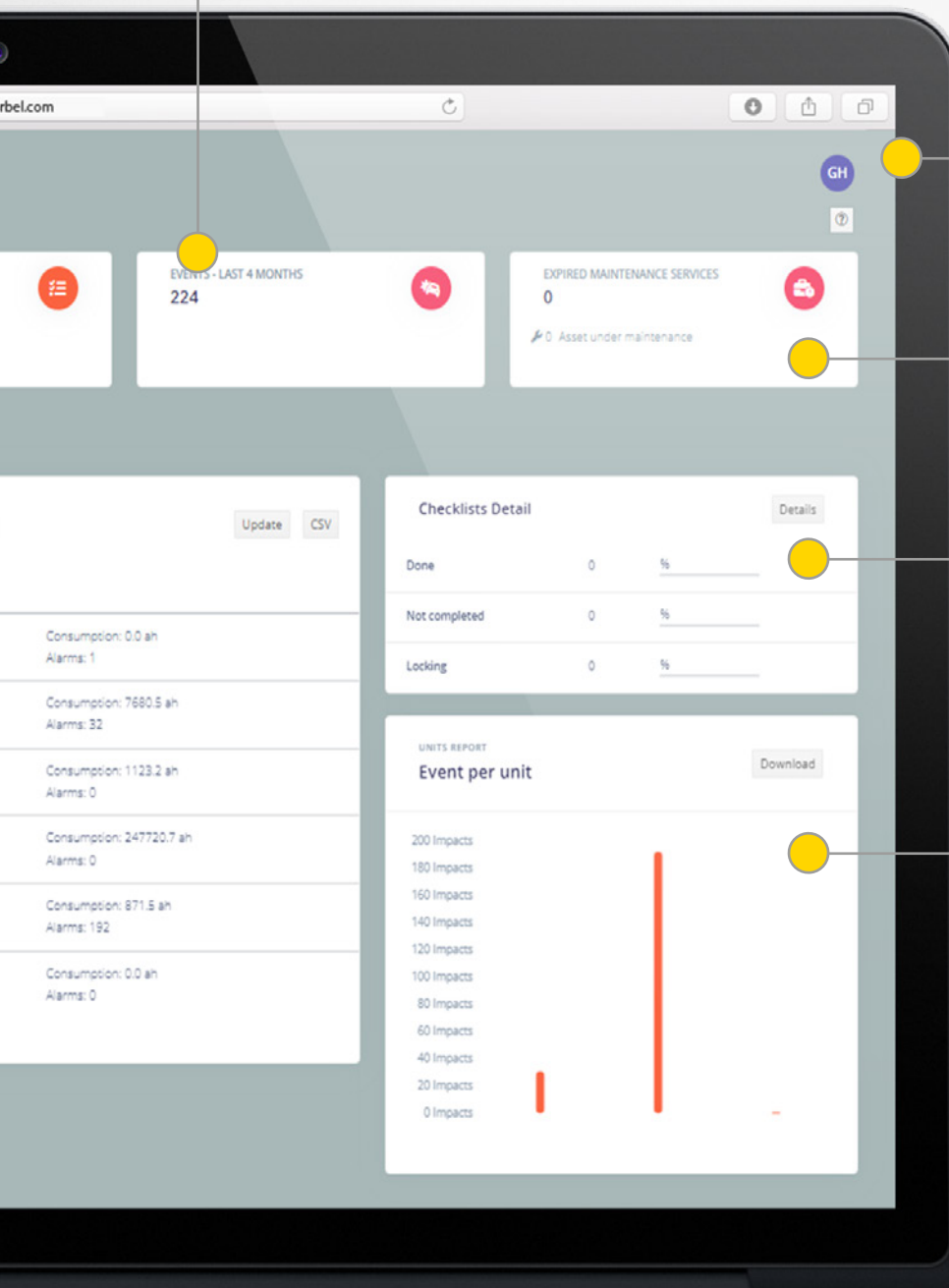

progress status of the checklists

EVENT PER UNIT

number of alarms that occurred within the time range chosen for each unit



MAIN FUNCTIONS OF G&W FLEET 4 YOU CONNECT

Nome	Info	Stato	Statistiche*
 RACER R 85 FD 65 BC PLUS FS	RACER R 85 FD 65 BC PLUS FS	604 h	21.2 h/giorno ? ah/giorno
 RACER R 85 FD 65 BC PLUS FS	RACER R 85 FD 65 BC PLUS FS	1339 h	7.9 h/giorno 64 ah/giorno
 RACER R 85 FD 65 BC PLUS FS	RACER R 85 FD 65 BC PLUS FS	99 h	1.7 h/giorno 12 ah/giorno
 RANGER R 115 FD 85 BC CHEM FS	RANGER R 115 FD 85 BC CHEM FS	0 h	0.0 h/giorno 0 ah/giorno
 Ranger R 115 FD 85 sn 01122019	Ranger R 115 FD 85	1425 h	0.1 h/giorno 0 ah/giorno
 ROUND 45 D 60 TOUCH BC CHEM FS	ROUND 45 D 60 TOUCH BC CHEM FS	18 h	0.1 h/giorno 11 ah/giorno

FLEET STATUS

All the fleet-related information:

- status of the machines (online, offline, turned off)
- hours worked and battery status
- latest uses of the machines
- location of the machines
- route taken by the machines
- work area management (ADL)

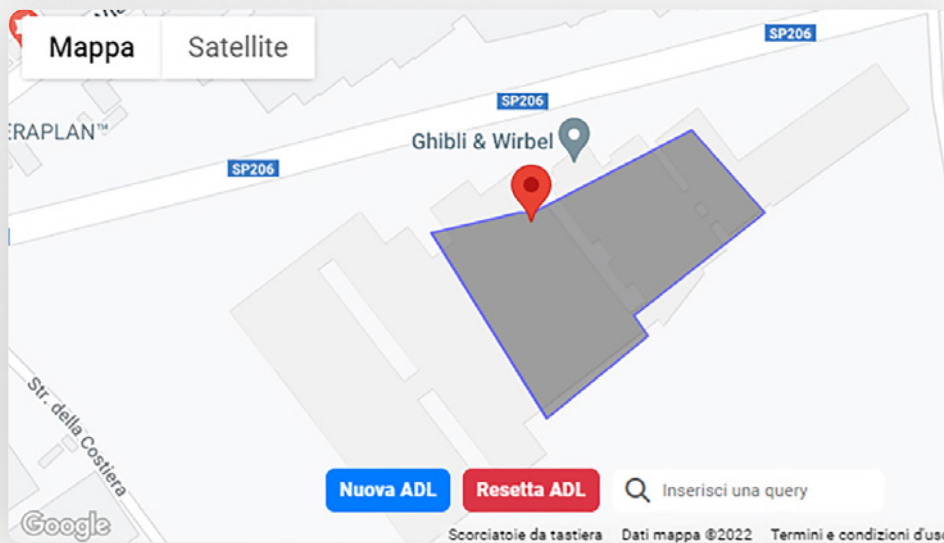

Mezzi: Commesse: Ricerca utente:

Tipologia di allarme: Data inizio: Data fine: Distanza:



GEOLOCATION

Checking the location and status of machines (online, offline, turned off) in real time.

▲ RACER R 85 FD 65 BC PLUS FS GPS	23 Sep 2022	B1 : 27
▲ RACER R 85 FD 65 BC PLUS FS GPS	22 Sep 2022	B1 : 22
▲ RACER R 85 FD 65 BC PLUS FS GPS	20 Sep 2022	B1 : 23
▲ RACER R 85 FD 65 BC PLUS FS GPS	20 Sep 2022	B1 : 22
▲ RACER R 85 FD 65 BC PLUS FS	20 Sep 2022	B1 : 21

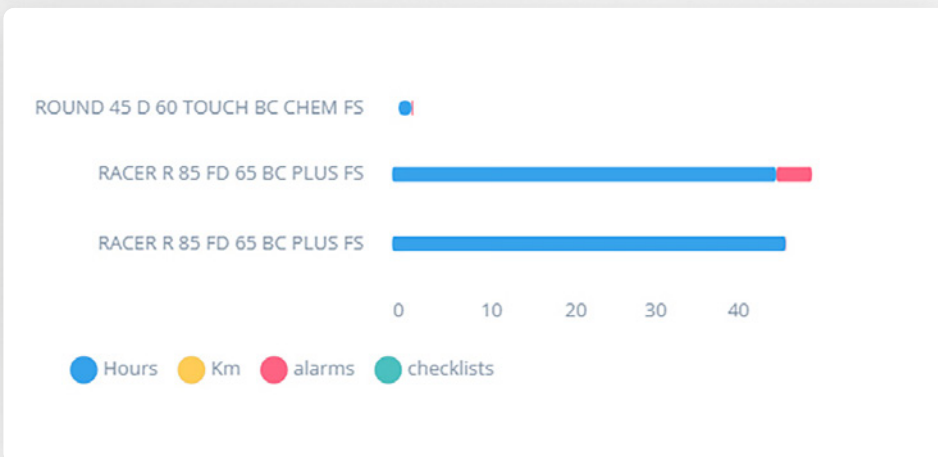
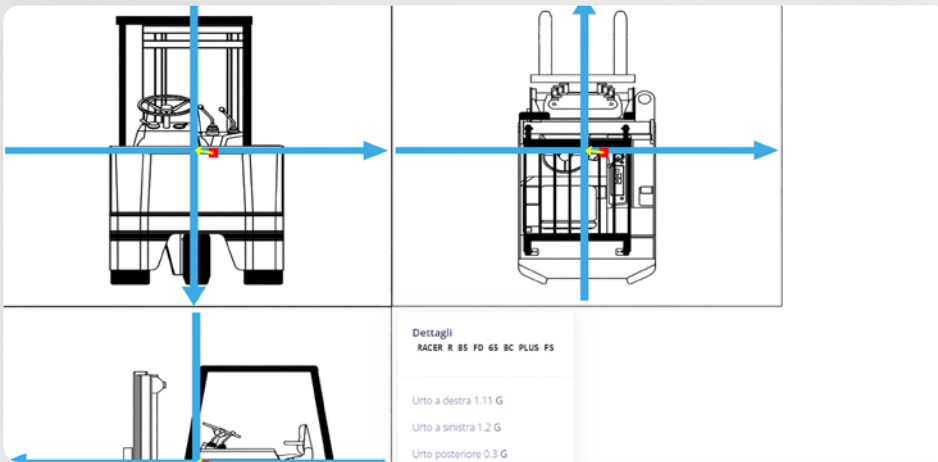

NOTIFICATIONS AND ALERTS

All the information pertaining to any eventual alarm:

- the machine that generated the signal;
- the date, time and place in which the alarm was generated;
- the affected sensor;
- the operator who was working the scrubber dryer at the time the alarm was set off;
- the type of collision suffered by the machine.

Notifications associated with alarms consist of e-mails, text messages, or web alerts that are generated and sent at the same time that an alarm is set off on a particular machine.

STATISTICS, UPDATED CHARTS AND CUSTOMIZABLE REPORTING

Data can always be easily exported (in CSV format).

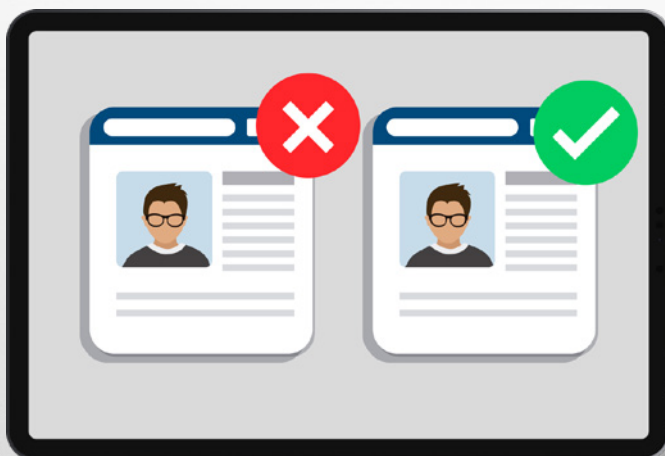

REMOTE MANAGEMENT OF THE ACCESSES

With G&W Fleet 4 You Connect you can easily enable/disable the operator from using the scrubber dryer directly from the cloud.

WALK BEHIND SCRUBBER DRYERS



ROUND 45

The scrubber dryer expressly designed to meet the most specific needs of cleaning professionals. The scrubber dryers feature the TOUCH SYSTEM, a patented, sensor-based system that allows the operator maximum flexibility and control while working with the machine. The state-of-the-art features and technical equipment, 45-liter of capacity, and three hours of autonomy make Round 45 an important point of reference in the industry, ideal for cleaning all surfaces and environments.

ROUND 45 M 55 TOUCH
ROUND 45 M 55 BC CHEM TOUCH

ROUND 45 D 55 TOUCH
ROUND 45 D 55 BC CHEM TOUCH
ROUND 45 D 60 TOUCH
ROUND 45 D 60 BC CHEM TOUCH



S2

The S2 scrubber dryer features a double brush, dual “modular” traction with differential (which provides excellent maneuverability), and extreme safety of use under all working conditions. It is an ergonomically designed, solid, powerful and reliable machine. Adjustable steering handle. Simple and intuitive dashboard equipped with diagnostics, hour counter and potentiometer to set the working speed.

S2 80 D 70
S2 80 D 70 BC



RIDE-ON SCRUBBER DRYERS



RACER R 85

The ideal ride-on scrubber dryer for medium-sized areas. 85-liter capacity, with different cleaning widths (650 and 750 mm) specifically designed to ensure the best cleaning results. Compact and extremely manoeuvrable, Racer is able to move smoothly even in the tightest and most congested spaces.

RACER R 85 FD 65
RACER R 85 FD 65 BC
RACER R 85 FD 65 BC PLUS
RACER R 85 FD 65 BC LITHIUM

RACER R 85 FD 75
RACER R 85 FD 75 BC
RACER R 85 FD 75 BC PLUS
RACER R 85 FD 75 BC LITHIUM



RANGER R 115

The ideal ride-on scrubber dryer for medium to large areas. 115 liters capacity, with different cleaning widths (750 and 850 mm) specifically designed to ensure the best cleaning results. Ranger is the perfect combination of productivity and manoeuvrability: it offers excellent performances even on large areas occupied by obstacles and, therefore, way more complex to clean.

RANGER R 115 FD 75 CHEM
RANGER R 115 FD 75 BC CHEM
RANGER R 115 FD 75 BC CHEM PLUS
RANGER R 115 FD 75 BC LITHIUM CHEM

RANGER R 115 FD 85 CHEM
RANGER R 115 FD 85 BC CHEM
RANGER R 115 FD 85 BC CHEM PLUS
RANGER R 115 FD 85 BC LITHIUM CHEM



RUNNER R 150

The ride-on scrubber dryer designed for large spaces. The necessary choice for those looking for power, reliability and top performances without sacrificing the comfort. The 150-liter capacity and wide cleaning widths (850 mm and 1000 mm) combined with a productivity of about 6000 m²/h ensure excellent cleaning results in large areas. The wide and “responsive” squeegee ensures top drying results on any kinds of surface.

RUNNER R 150 FD 85 CHEM
RUNNER R 150 FD 85 BC CHEM
RUNNER R 150 FD 100 CHEM
RUNNER R 150 FD 100 BC CHEM



R R 300

The ideal ride-on scrubber dryer for cleaning large areas. As a matter of fact, the 300-liter capacity and wide cleaning widths (1100 mm and 1300 mm) ensure productivity up to 10400 m²/h. Powerful, sturdy and reliable, R 300 can tackle the most difficult and stubborn dirt and work in wide environments such as parking lots, warehouses, production and logistics departments.

R R 300 FD 110 CHEM
R R 300 FD 110 BC CHEM
R R 300 RD 110 CHEM
R R 300 RD 110 BC CHEM

R R 300 FD 130 CHEM
R R 300 FD 130 BC CHEM
R R 300 RD 130 CHEM
R R 300 RD 130 BC CHEM

ghibli & wirbel

Professional Cleaning Machines Since 1968



100% MADE IN ITALY

Ghibli & Wirbel S.p.A.

Registered office

Via Enrico Fermi, 43 - 37136 Verona (VR) - Italy

Headquarters

Via Circonvallazione, 5 - 27020 Dorno (PV) - Italy

P. +39 0382 848811 - F.+39 0382 84668 - M. info@ghibliwirbel.com

www.ghibliwirbel.com

